



PRODUCT SHEET

BRIDGE GUARD DAV H2/W1

The newly developed bridge guard, DAV H2/W1 is CE marked according to European standards and meets the requirements of EN 1317-2 and EN 1317-5.

With a sceptre distance of 3.0 meters, the bridge guard can be mounted on bolt groups. The bridge guard can be mounted with or without B-profiles, completely according to the customer's wishes, and with or without filling rods.

- All reject beams are horizontal and with deformation brackets, which ensures an ASI value B.
- The A-bracket ensures power transmission.
- The railing is at least corrosion protected to C3.
- Bolts are provided with rounded heads to avoid protruding edges.

The Bridge Guard is not CE marked

- with lengths \leq 36,6 m.
- up to radius < 100 m.
- at descents and at mounting on foundations

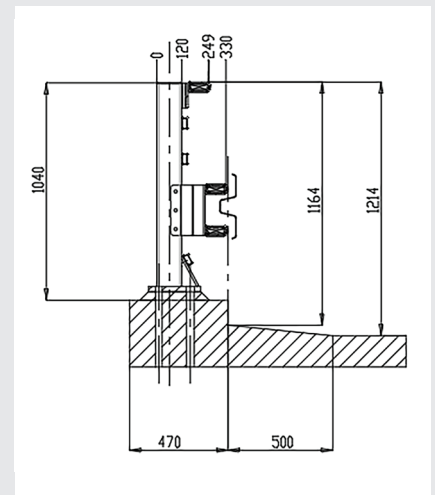

DAV H2/W1 is used on bridge constructions where regular requirements are set for a CE marked bridge guard.

Scepter-distance, m	Height, m	Strength class	Workingwidth	ASI-value	Testdistance, m
3.00	1.20	H2	W1	B	36.6